



A new range of CCM03 connectors have been developed to interface with SIM/SAM cards as defined by GSM11-11 and ENV1375-1. The connectors are available with either hinged covers or fixed covers and have been designed to minimize the amount of space needed for PCB mounting.

Features

Hinged Cover

- Available with 6 or 8 contacts, with or without PCB locating pegs.
- Available with card presence switch.
- The cover springs open when unlocked while the card is in place.
- The molding is polarized so that the cover can only be closed if the card is correctly inserted.
- The cover can be replaced without removing the connector from the PCB
- Inspection slots allow an electrical test to be made without opening the cover.
- The overall height of the connector is only 2.5 mm. The amount of space needed to mount the connector is just 29.65 mm x 17.2 mm

Fixed Cover

- Available with 6 or 8 contacts.
- The overall height of the connector is 2.85 mm max. Only 25.5 mm x 17.2 mm of board space is required to mount the connector.

General

- With tape and reel packaging as standard, the connectors are designed to be automatically pick-and-placed.
- The high temperature thermoplastic moldings are suited for infrared and convection soldering processes.
- By using an inlay finish in the contact area the life of the precious metal is extended by over 10 times that of standard gold plating.
- Robustly formed printed circuit tails allow a co-planarity of ± 0.05 mm to be maintained.

Construction	
Contacts	Copper alloy
Plating	Contact area : Gold alloy inlay Terminals : Tin lead (2 μ min)
Moldings	High temp. thermoplastic UL 94V-0 rated
Spring	Stainless steel

Mechanical data	
Number of Contacts	6 or 8
Mechanical life, hinged cover	10,000 cycles min
Mechanical life, fixed cover	50,000 cycles
Durability of inlay, hinged cover	10,000 cycles min (see note 1)
Durability of inlay, fixed cover	5,000 cycles
Card insertion force	Hinged cover: 1 N max Fixed cover: 3 N max
Card extraction force	Hinged cover: 1 N max Fixed cover: 0.80 N min / 3 N max
Contact force	0.25 N min / 0.50 N max
Slide locking force	2 N min / 6 N max
Vibration	Frequency 10 to 500 Hz. Acceleration 50m/s ² Duration 6 hours - amplitude 0.35 mm Max electrical discontinuity 1 μ s
Shock	Peak value 500 m/s ² - Duration 11 ms 3 shocks in each direction of each axis Max electrical discontinuity 1 μ s

Electrical data	
Insulation resistance	1,000 M Ω min
Contact resistance max	100 m Ω max
Switching current	10 μ A min / 1 A max
Dielectric strength	750 Vrms min

Environmental data	
Operating temperature	-40°C to +85°C
Soldering temperature	Temperature/time profile acc. to CECC00802 para. 6.1, Fig. 3 with peak temperature 250°C
Damp heat	IEC 512 test number 11c (10 days)
Salt mist	IEC 512 test number 11f (96 hours)

Note 1: Inlay (precious metal) rating is based on a very abrasive card being used and is intended to represent worst case.

CCM03 MK II

Ordering code

Part Number	N° of Contacts	Cover	PCB Locating Pegs (mm)	Stand off (mm)	Quantity per reel	Metal lock	Switch lock	Card Presence switch
CCM03-3001 R102	6	Hinged	No	0.00	1000	Flat	No	No
CCM03-3002 R102	6	Hinged	Yes	0.00	1000	Flat	No	No
CCM03-3003 R102	8	Hinged	No	0.00	1000	Flat	No	No
CCM03-3004 R102	8	Hinged	Yes	0.00	1000	Flat	No	No
CCM03-3005 R701**	6	Hinged	No	1.90	700	Bump	No	No
CCM03-3006 R701**	6	Hinged	Yes	1.90	700	Bump	No	No
CCM03-3007 R701**	8	Hinged	No	1.90	700	Bump	No	No
CCM03-3008 R701**	8	Hinged	Yes	1.90	700	Bump	No	No
CCM03-3009 R102	6	Hinged	No	0.00	1000	Bump	No	No
CCM03-3013 R102	6	Hinged	No	0.00	1000	Bump	No	Yes
CCM03-3504 R122	8	Fixed	No	0.00	1200	No	No	No
CCM03-3505 R122	6	Fixed	No	0.00	1200	No	No	No
CCM03-3512 R102*	6	Hinged	No	0.00	1000	Bump	No	No
CCM03-3514 R102	6	Hinged	No	0.00	1000	Bump	Yes	No

*Note: Terminal width = 1 mm - Length = 1.5 mm. (For double reflow).

**Note: On request - Depending on quantities.

Packaging

CCM03 are packaged in accordance with EIA 481-3.

Standard packaging is on tape and reel.

A modification code is added to the part number that indicates reel packaging and the number of components per reel. There are 5 reels per box.

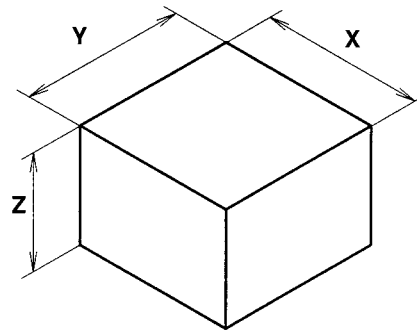
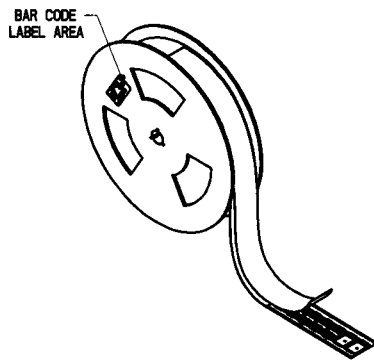

Reel Diameter	Reel Width	X	Y	Z
360 mm	24.4 mm	344 mm	350 mm	152 mm

CCM03 MK II Hinged Cover

Dimensional Drawings

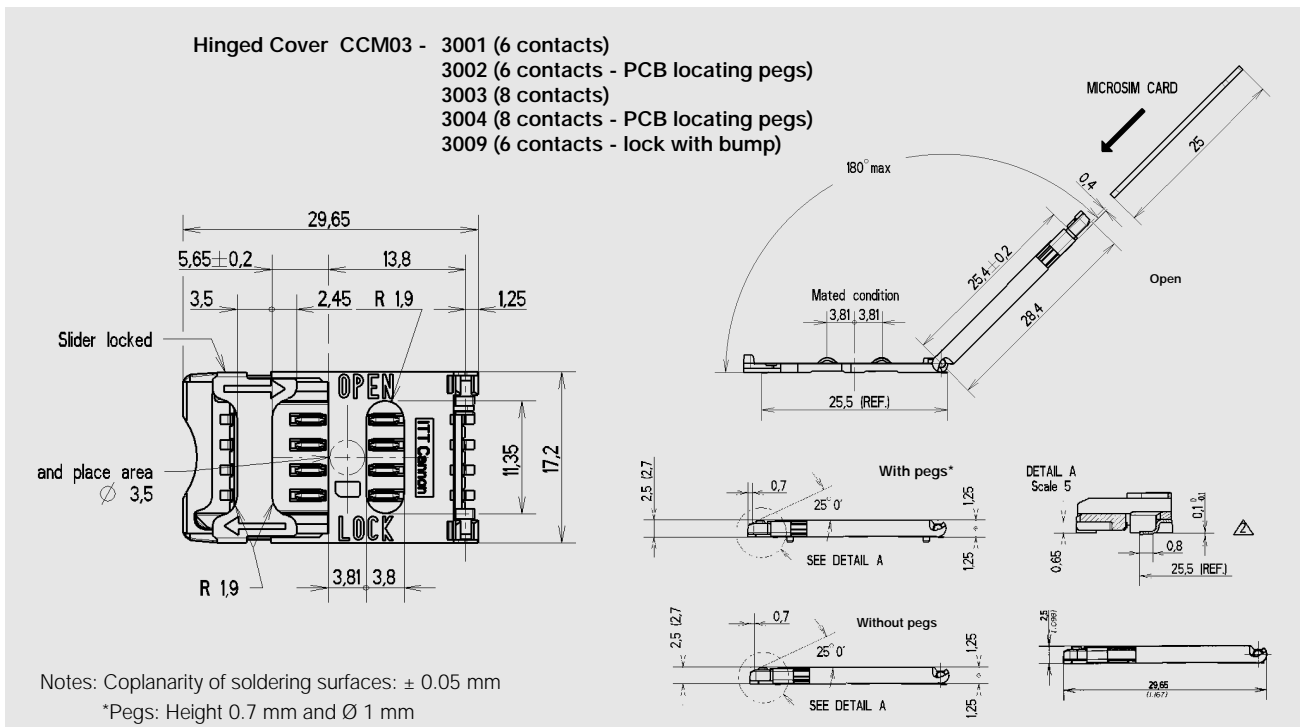

PCB Layout

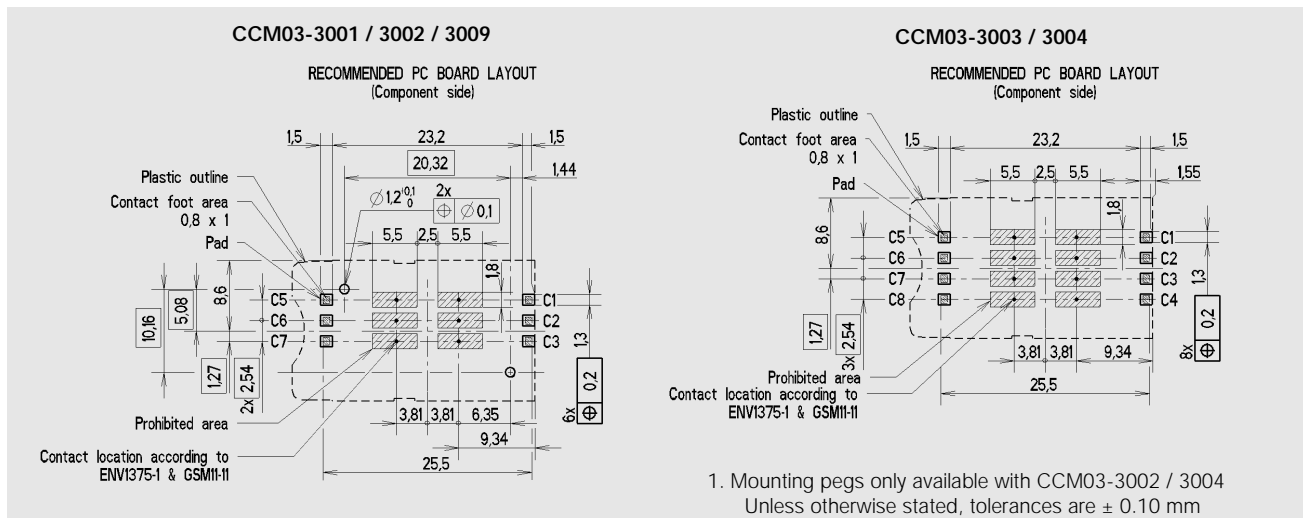

CCM03 MK II Hinged Cover

Dimensional Drawings

Hinged Cover CCM03 - 3005 (6 contacts - with stand off 1.90 mm)

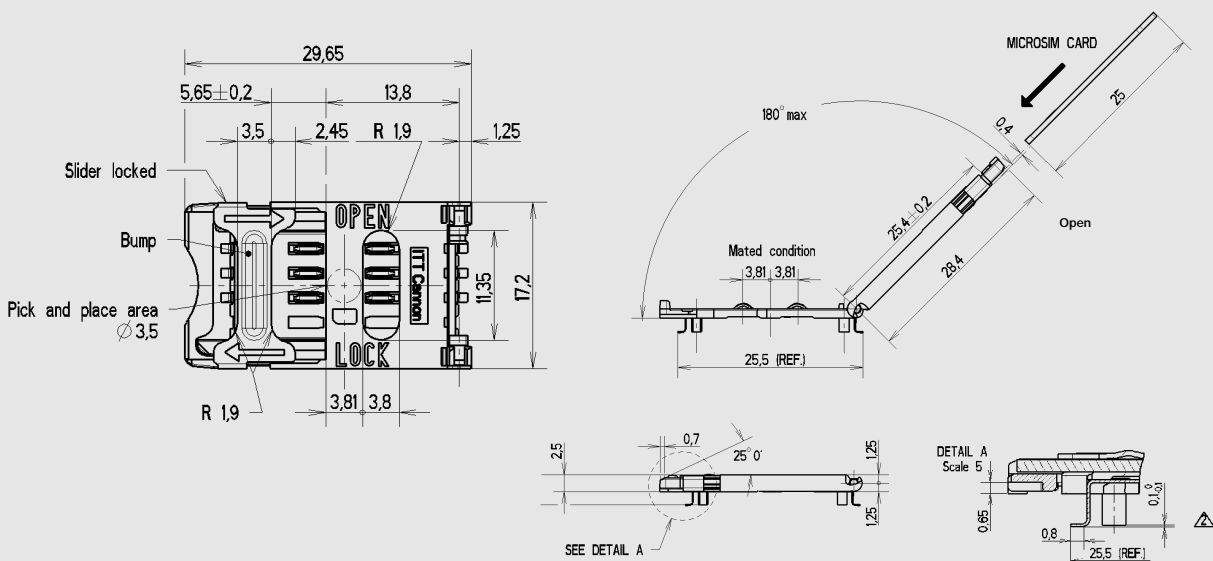

PCB Layout

CCM03-3005

RECOMMENDED PC BOARD LAYOUT
(Component side)

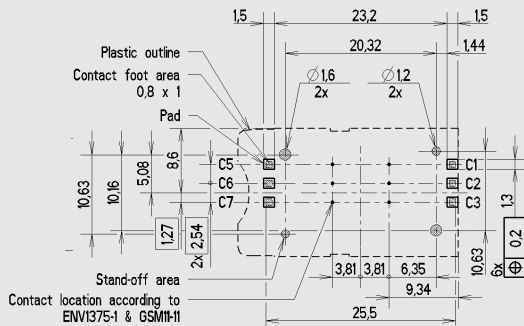

Unless otherwise stated, tolerances are ± 0.10 mm

CCM03 MK II Hinged Cover

Dimensional Drawings

Hinged Cover CCM03 - 3006 (6 contacts - with locating pegs 1.90 mm)

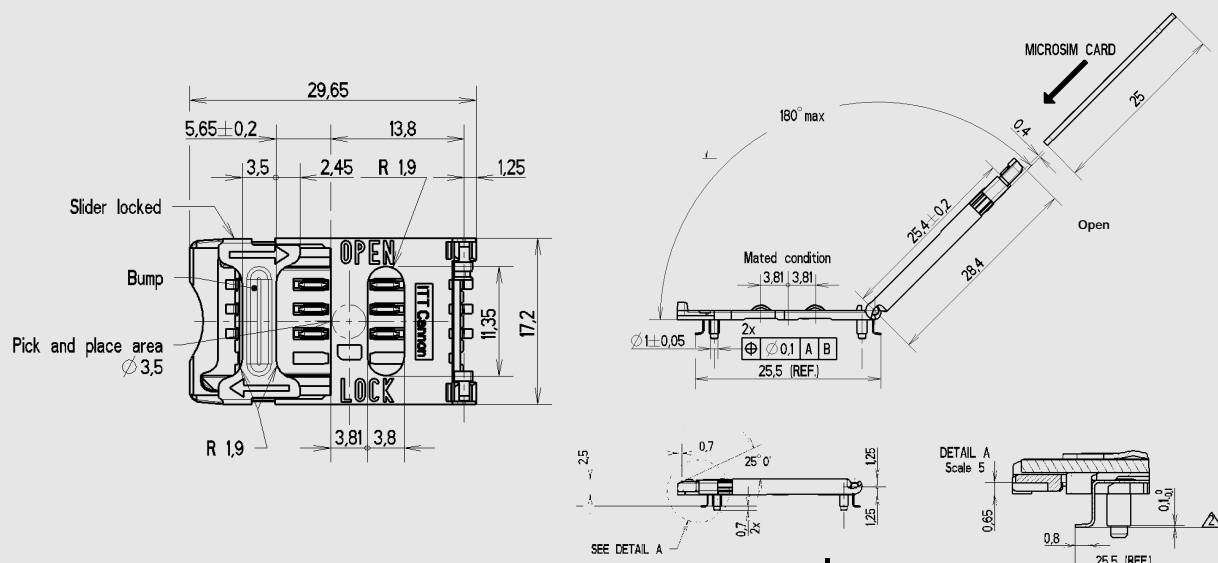

Note: Coplanarity of soldering surfaces: ± 0.05 mm

PCB Layout

CCM03-3006

RECOMMENDED PC BOARD LAYOUT
(Component side)

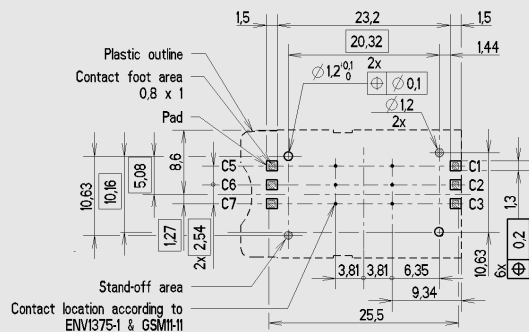

Unless otherwise stated, tolerances are ± 0.10 mm

CCM03 MK II Hinged Cover

Dimensional Drawings

Hinged Cover CCM03 - 3007 (8 contacts - with stand off 1.90 mm)

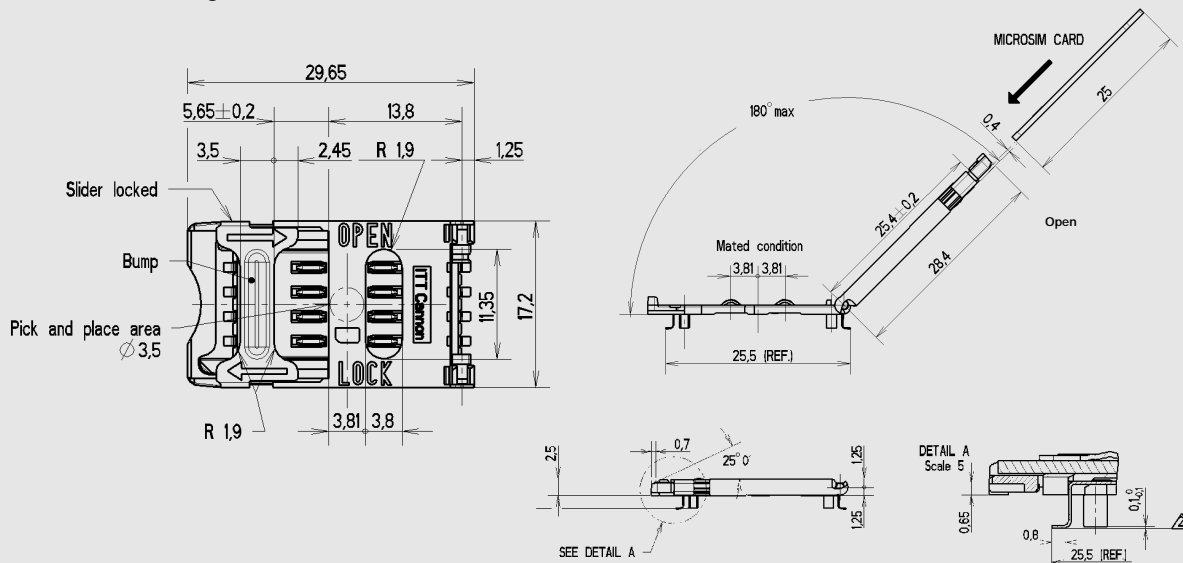

Note: Coplanarity of soldering surfaces: ± 0.05 mm

PCB Layout

CCM03-3007

RECOMMENDED PC BOARD LAYOUT
(Component side)

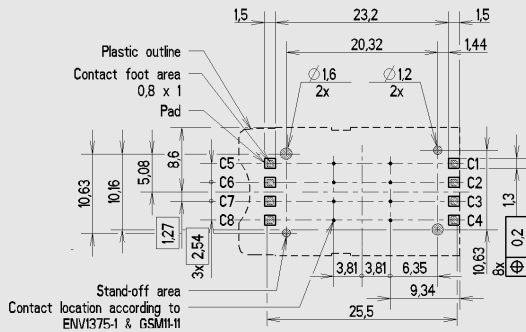

Unless otherwise stated, tolerances are ± 0.10 mm

CCM03 MK II Hinged Cover

Dimensional Drawings

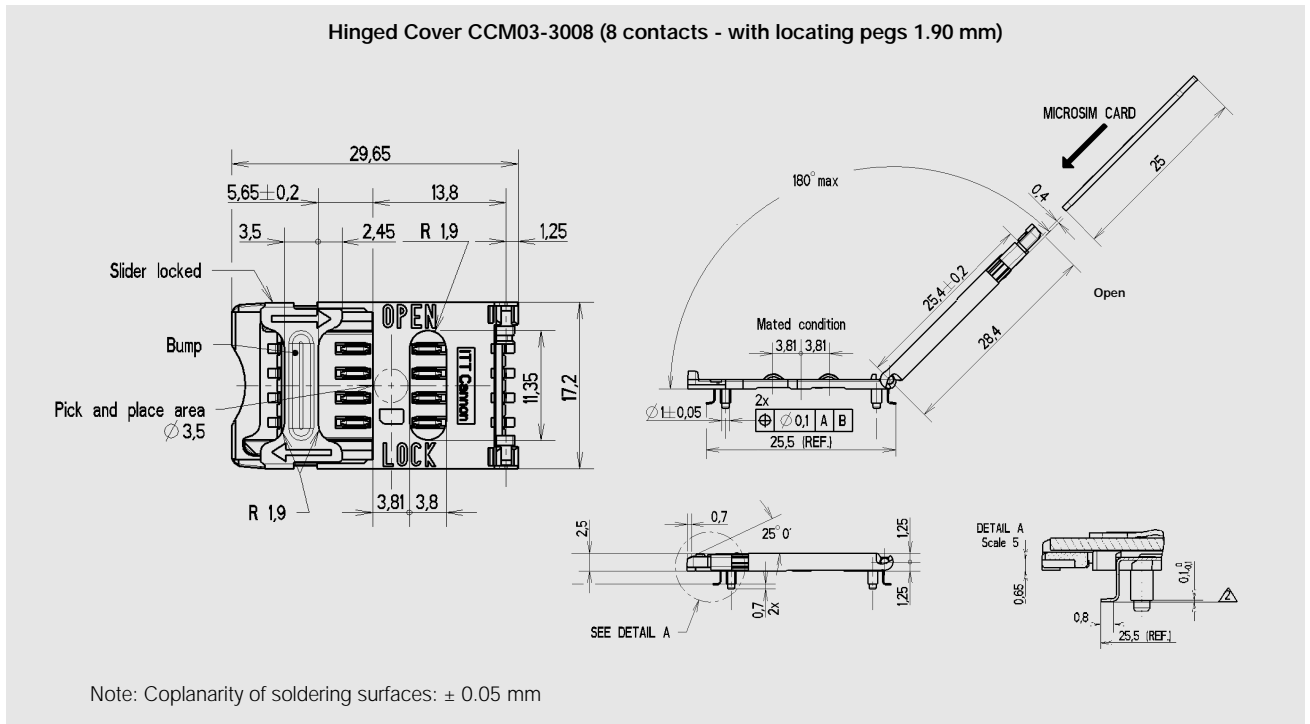

PCB Layout

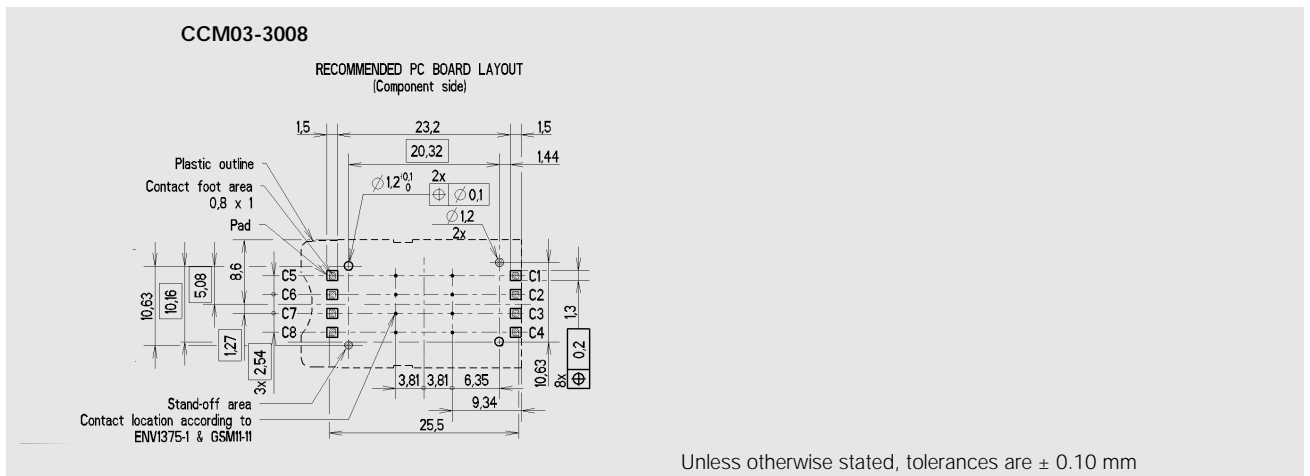

CCM03 MK II Hinged Cover



Dimensional Drawings

Hinged Cover CCM03-3013 (6 contacts + Card Detect Switch)

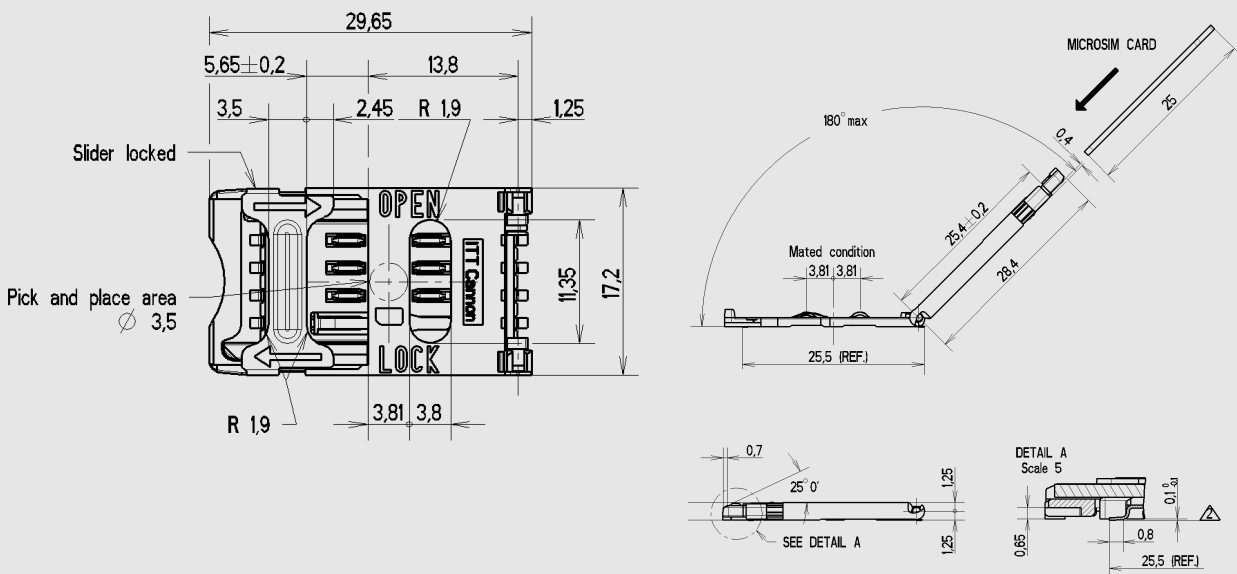

Note: Coplanarity of soldering surfaces: ± 0.05 mm

PCB Layout

CCM03-3013

RECOMMENDED PC BOARD LAYOUT
(Component side)

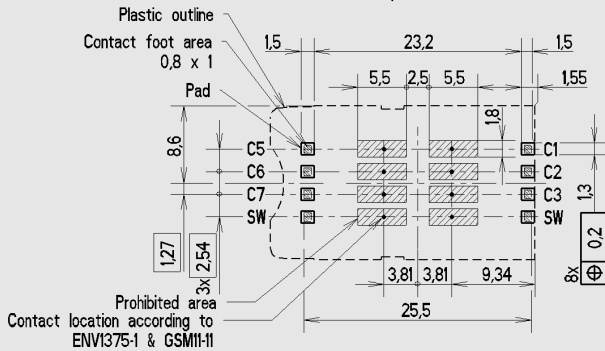

Unless otherwise stated, tolerances are ± 0.10 mm

CCM03 MK II Fixed Cover

Dimensional Drawings

Fixed cover CCM03-3505 (6 contacts not shown) / CCM03-3504 (8 contacts)

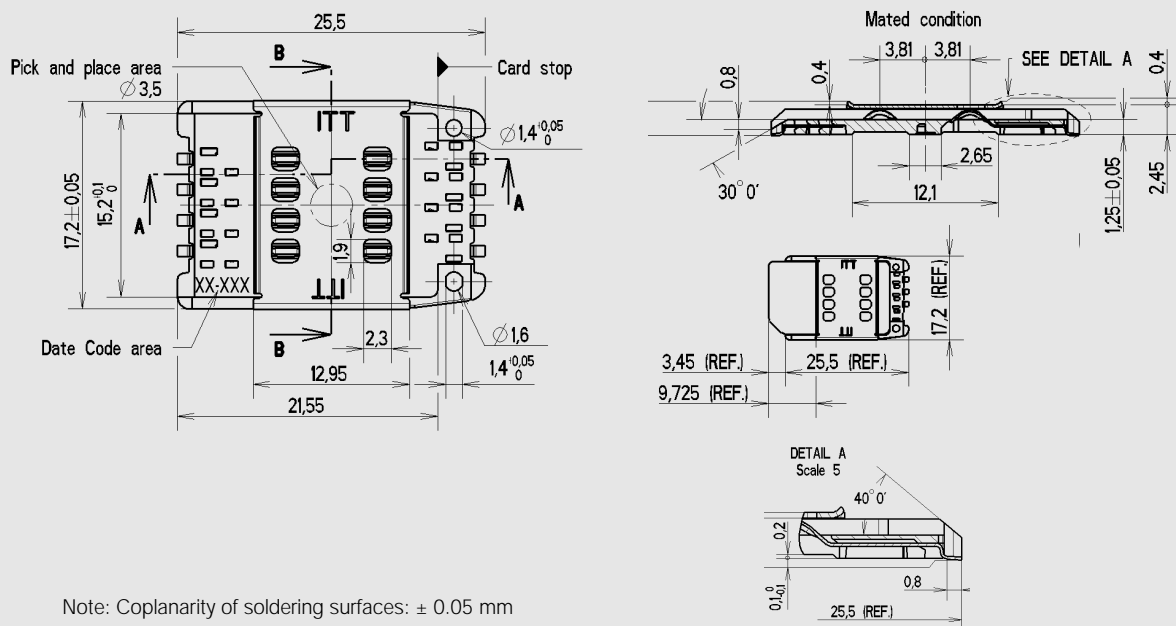

PCB Layout

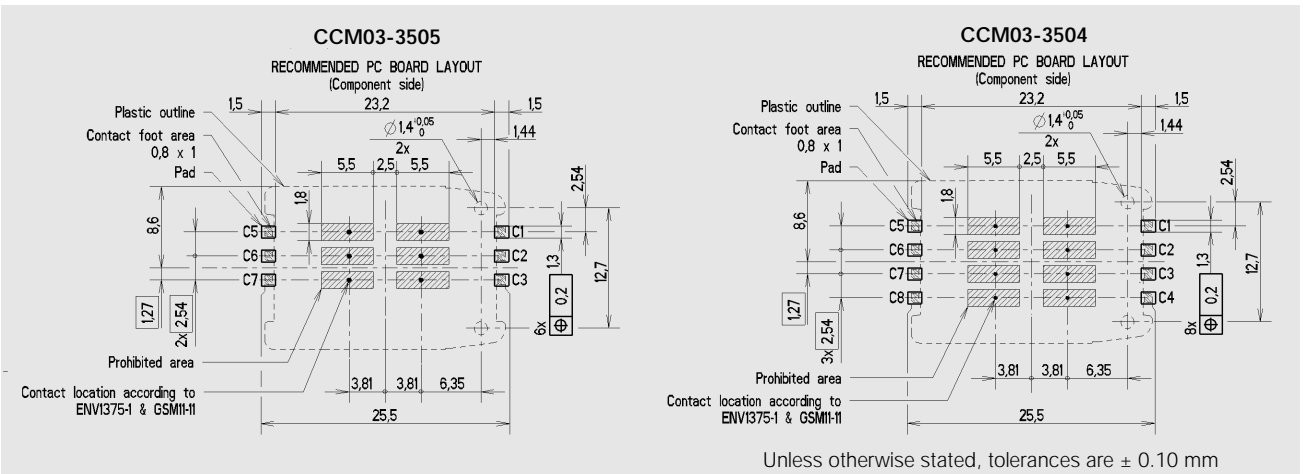

CCM03 MK II Hinged Cover



Dimensional Drawings

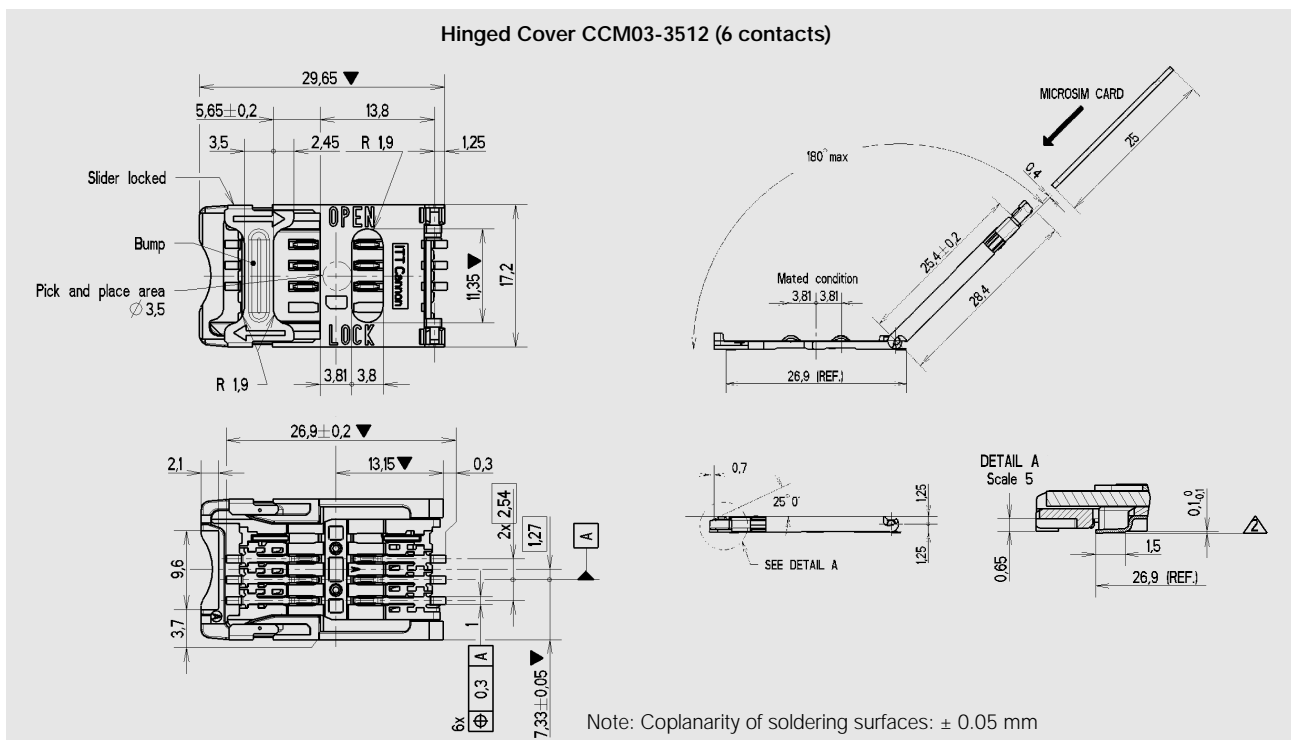

PCB Layout

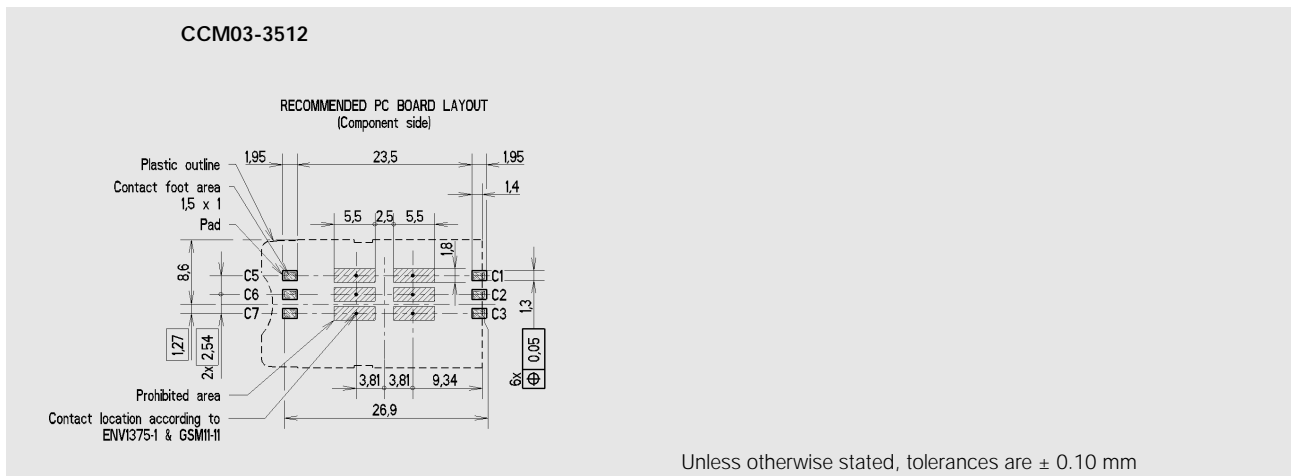

CCM03 MK II Hinged Cover



Dimensional Drawings

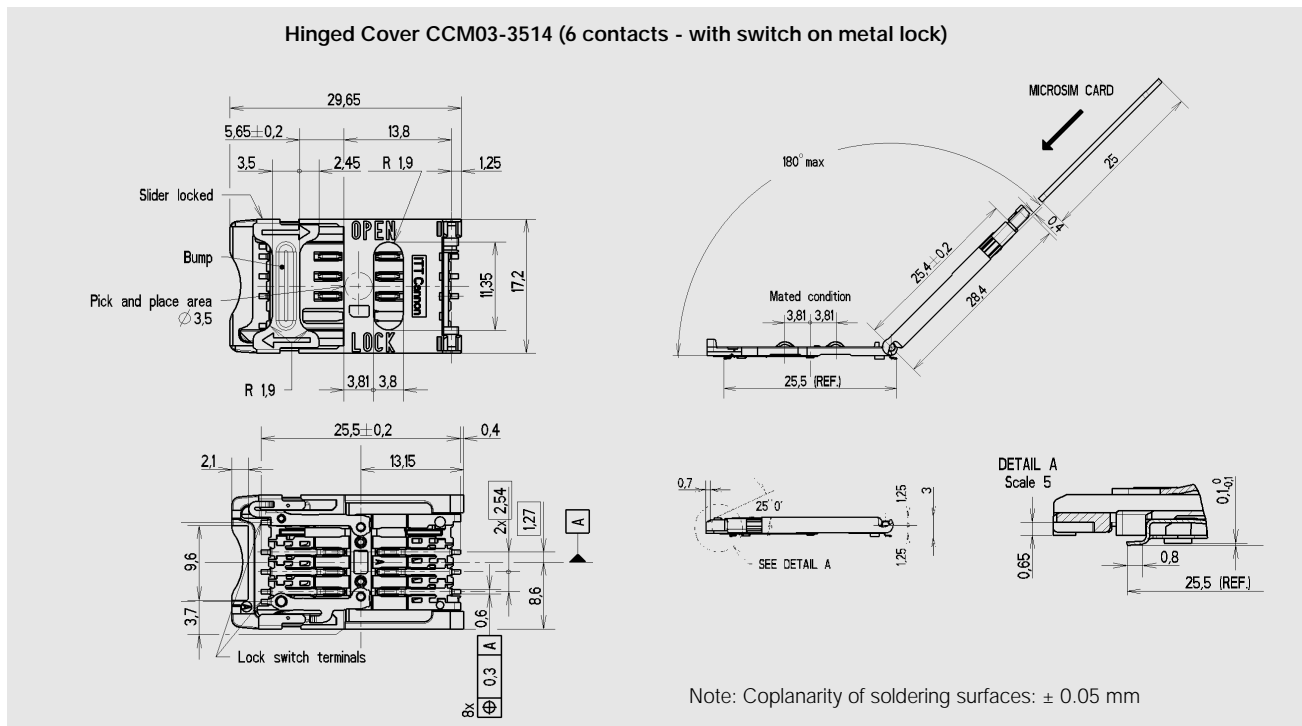

PCB Layout

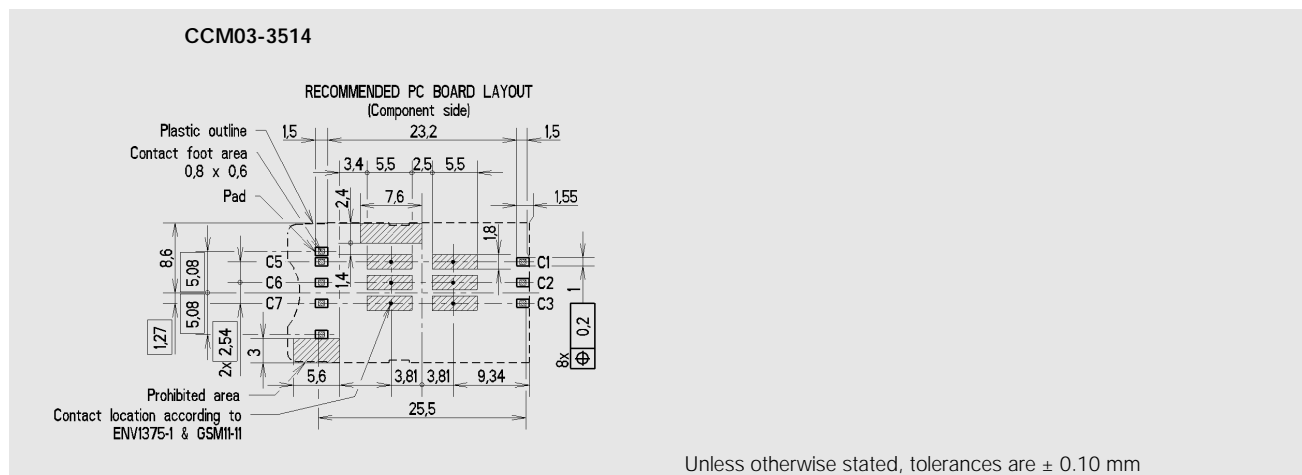

CCM03 MK II with Auto Lock cover



A new range of CCM03 connectors have been developed to interface with SIM/SAM cards as defined by GSM11-11 and ENV1375-1. The connectors are available with a hinged metallic cover and have been designed to provide an easier open/lock function and side card entry.

Features

- Available with 6 cross contacts which are designed to give a consistently reliable normal force over the life of the connector.
- The hinged metallic cover can automatically lock by pressure.
- Side entry of the card ensures easier positioning of the card into the connector.
- Blade switch version available for detection card when cover is closed.
- The molding is polarized so that the cover can only be closed if the card is correctly inserted.
- Inspection slots allow an electrical test to be made without opening the cover.

General

- With tape and reel packaging as standard, the connectors are designed to be automatically pick-and-placed.
- The moldings are made from high temperature thermoplastics suited to infra-red and convection soldering processes.
- By using an inlay finish in the contact area the life of the precious metal is extended by over 10 times that of standard gold plating.
- Robustly formed printed circuit tails allow a co-planarity of ± 0.05 mm to be maintained.

Construction	
Contacts	Copper alloy
Contacts finish	Gold alloy inlay (Au/Ag/Pd)
PC tail plating	Tin lead (2 μ min) Sn/Pb
Molding	High temp. thermoplastic, UL94V-0
Cover	Stainless steel

Mechanical data	
Number of Contacts	6
Mechanical life	10,000 cycles min
Durability of inlay	10,000 cycles min
Contact force	0.25 N min / 0.50 N max
Vibration	Frequency 10 to 500 Hz. Acceleration 50m/s ² Duration 6 hours - amplitude 0.35 mm (0.014) Max electrical discontinuity 1 μ s

Electrical data	
Insulation resistance	1,000 M Ω min
Contact resistance	100 m Ω max
Signal current rating	10 μ A min / 1 A max
Dielectric strength	750 Vrms min
Card detection switch	Normally open
Switch contact resistance	100 m Ω max
Dielectric strength switch	250 Vrms min
Switch current rating	1mA min / 10m A max
Maximum switch power	0.2 VA

Environmental data	
Operating temperature	-40°C to +85°C
Soldering temperature	Temperature/time profile acc. to CECC00802 para. 6.1, Fig. 3 with peak temperature 250°C
Damp heat	IEC 512 test number 11c (10 days)
Salt mist	IEC 512 test number 11f (96 hours)

Ordering Code				
Part Number	N° of Contacts	Cover	Card Presence Switch	Quantity per reel
CCM03-3517	6	Hinged	No	1300
CCM03-3518	6	Hinged	Yes	1300

CCM03 MK II with Auto Lock cover

Dimensional Drawings

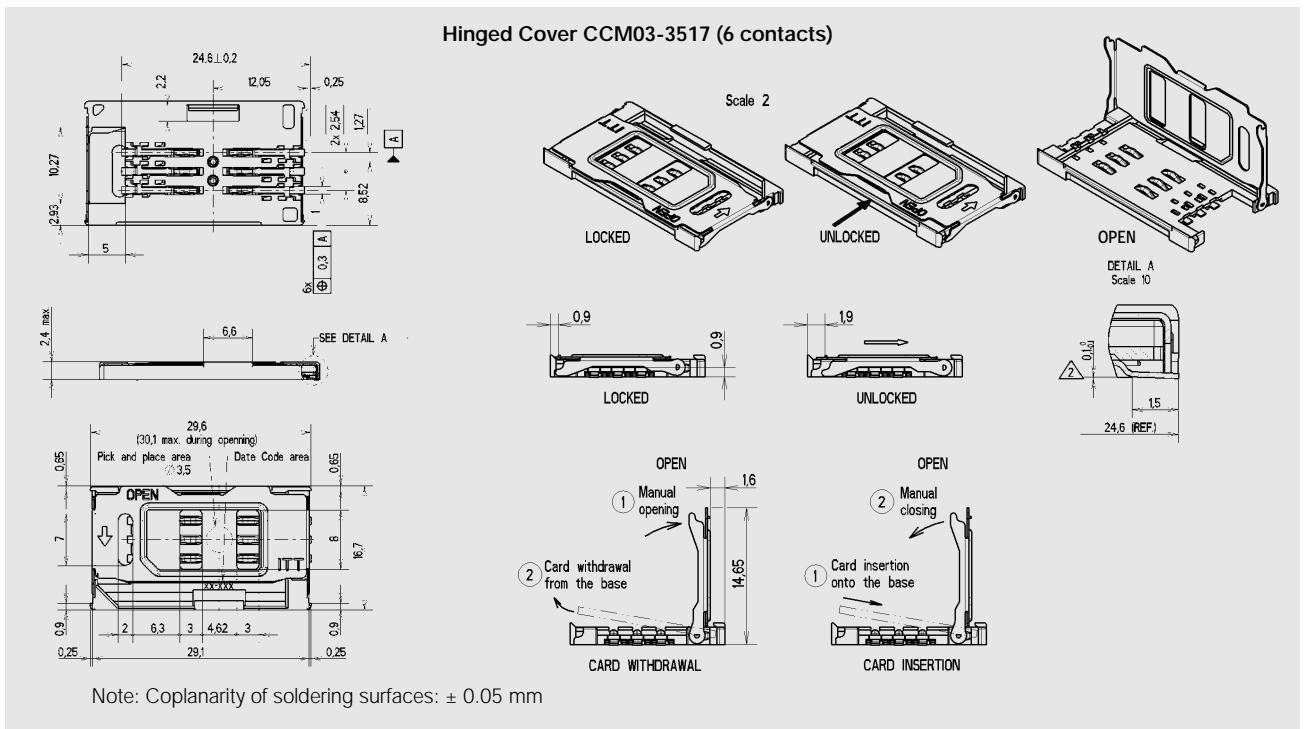

PCB Layout

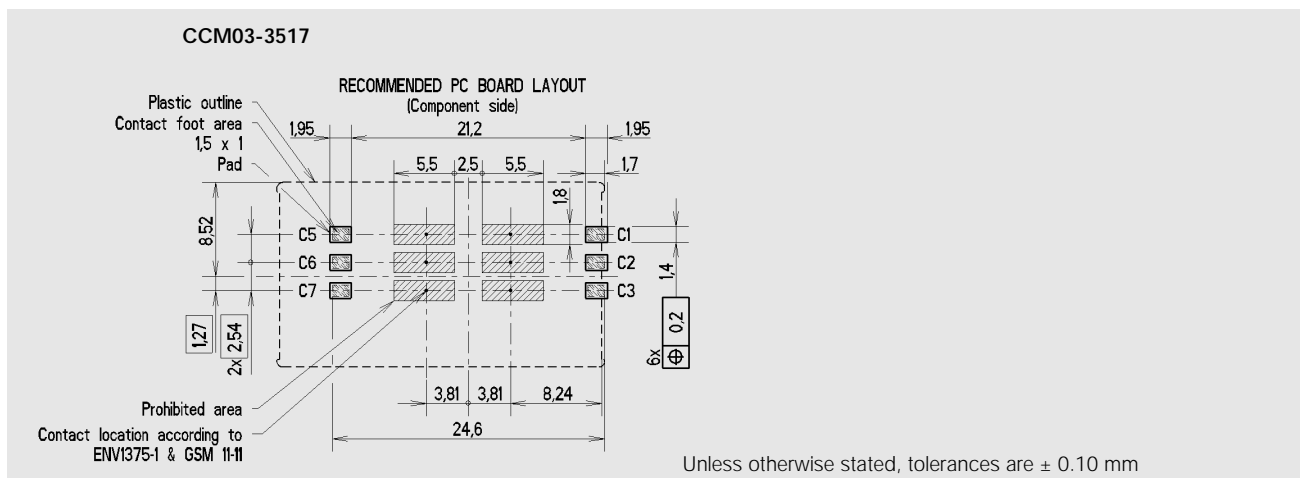

CCM03 MK II with Auto Lock cover

Dimensional Drawings

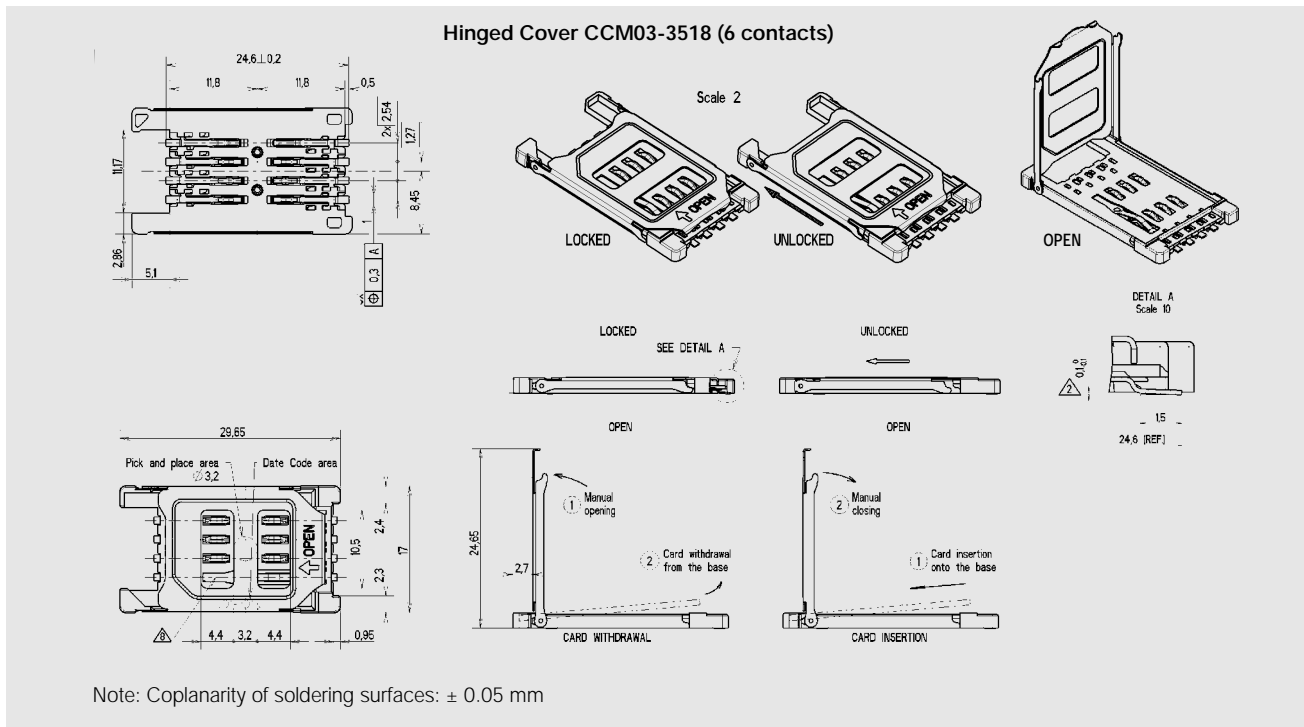

PCB Layout

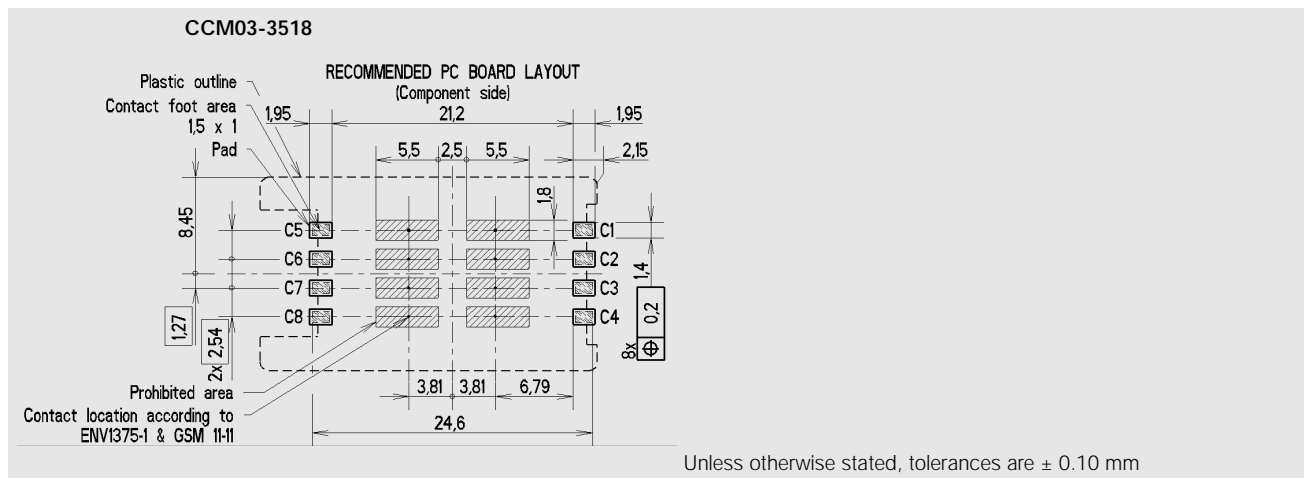



Introducing the new CCM03 Series SIM/SAM Card Connector from ITT Cannon Switch Products, featuring an integrated card detection switch. This connector provides a competitive advantage to smart card reader device manufacturers by minimizing the space usage on the PCB, and features a side entry to offer convenient card access without opening the device. The unique design of this compact-size connector makes it ideal for telecommunications, portable electronics, POS terminals and similar applications, and meets GSM 11-11 and EMV specifications.

Features

- Unique card-guiding design.
- 6 spoon-shaped, gold-alloyed contacts resist wear and improve connectivity.
- Sealed card detection switches reduce connectivity problems caused by dust or moisture.
- Switch design detects and holds the card while providing firm contact.
- Unique side entry design offers card access without opening the device.
- Stainless steel cover and UL 94VO high-temperature thermoplastic insulator.

Construction	
Insulator	High temperature thermoplastic UL 94V.0
Contacts	Copper Alloy
Contact finish	Gold Alloy Inlay (Au / Ag / Pd)
PC Tail plating	Tin lead (2 μ m min) Sn / Pb

Mechanical data	
Mechanical life	10,000 cycles minimum
Precious metal	5000 cycles minimum (see note 1)
Contact force	0.25N min / 0.5N max

Electrical data	
Insulation resistance	1000 M Ω min
Contact resistance max	100 m Ω max
Switching current	10 μ A min / 1 A max
Dielectric strength	500 Vrms min

Environmental data	
Operating temperature	-40°C to +85°C
Soldering temperature	Temperature/time profile acc. to CECC00802 para. 6.1, Fig. 3 with peak temperature
Salt mist	IEC 512 test number 11f (96 hours)
Damp heat	IEC 512 test number 11c (10 days)

Note 1: Inlay (precious metal) rating is based on a very abrasive card being used and is intended to represent worst case.

Ordering Code					
Part Number	N° of Contacts	Cover	Switch Testing Hole	Ground Terminal	Quantity per reel
CCM03-3752 R102	6	Without chamfer	Yes	No	1000
CCM03-3753 R102	6	With chamfer	No	No	1000
CCM03-3754 R102	6	With chamfer	Yes	No	1000
CCM03-3757 R102	6	With chamfer	No	Yes	1000
CCM03-3758 R102	6	With chamfer	Yes	Yes	1000

CCM03 MK III

Dimensional Drawings

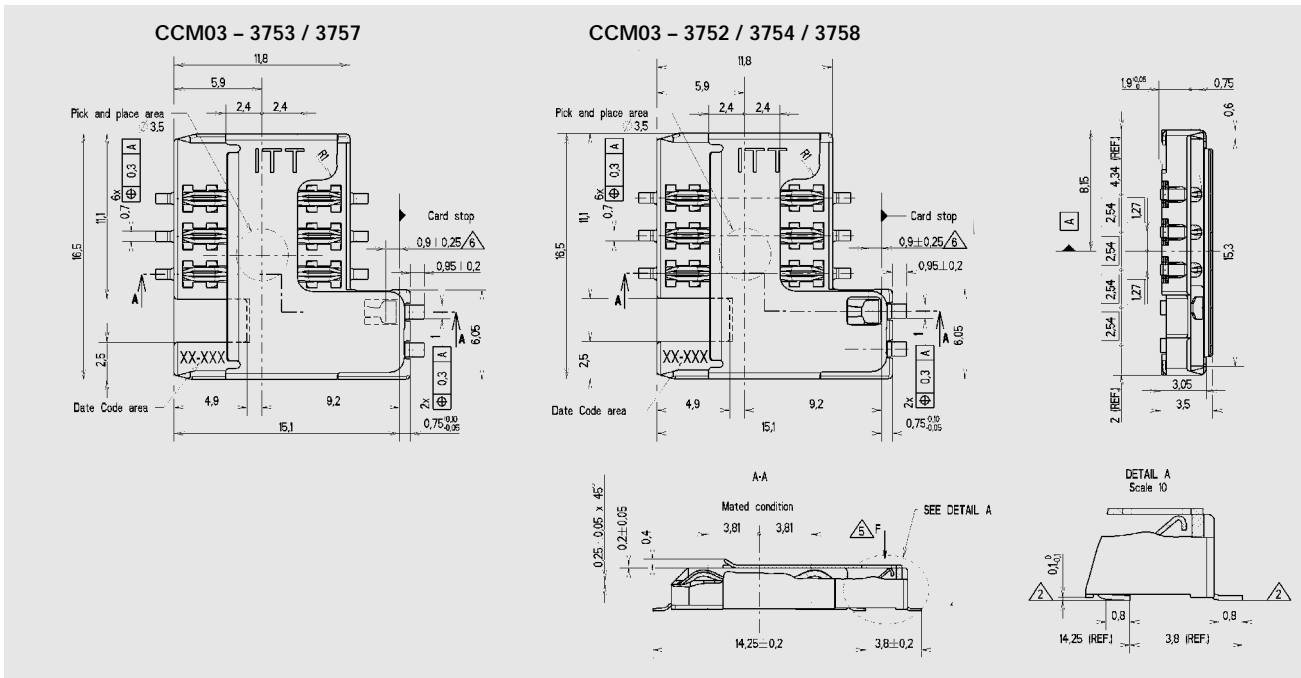

PCB Layout

